



VORTEX BLUE OIL RANGE

Internal and external blue flame
oil-fired condensing boilers with
outputs from 15kW to 36kW



VortexBlue External Range



At Grant we have been designing and manufacturing reliable and easy to install heating products for four decades. From award winning oil-fired condensing boilers to the latest renewable technologies, our heating systems have a reputation for quality that is second to none.

We combine precision engineering, innovation, performance and value for money to produce sustainable heating solutions that are trusted by both installers and householders.

Quality Design

There is never a compromise on quality. We design all of our products so that you can be sure that the durability and efficiency are sector leading. We continually develop new technologies and use only the best materials to ensure our products exceed all performance and environmental standards.

Our belief in simple solutions ensures that, while our technology is sophisticated, our products are low maintenance and easy to install. For a high quality, reliable and sustainable heating system, trust in Grant.

Heating Responsibly

Grant manufacture heating systems that respond to the challenges of rising fuel costs whilst protecting our environment. Environmental responsibility is central to all we do and we continue to develop and innovate to produce even more efficient products that make best use of our natural resources.

We are passionate about developing sustainable, high-performance and affordable alternatives for heating homes into the future.

Our Guarantee

The Grant label is a guarantee of reliability, quality and value. We put our customers first and our independence ensures that we can monitor our standards and processes to deliver the very best quality and service.

That's why, when you order your system from a Grant stockist, you can be sure of a tailored service and excellent after sales support.

Blue Flame Technology

What is a Blue Flame boiler?

Grant VortexBlue Blue Flame boilers incorporate the very latest oil burner technology. For over 2 years both Grant and Riello's R&D teams have worked together on a joint initiative to develop a compact Blue Flame burner and match this to Grant's Vortex condensing oil boiler range.

The principle of combustion differs from that of a Yellow Flame burner in that the combustion gasses are re-circulated through a specially designed blast tube, allowing them to mix with atomised droplets of fuel and fresh air (oxygen) drawn in through the burner, to produce a clean blue flame with far lower NOx emissions.

Why do we need to consider changing to Blue Flame technology?

In 2018, oil fired boilers installed in the UK have to meet lower NOx emission targets. Furthermore, it is likely that even more stringent emission levels will be set in future years, so Grant have taken the decision to try and future proof oil fired appliances by moving to very low NOx, Blue Flame technology today.

Pluming

Grant VortexBlue condensing boilers operate at extremely high efficiency levels, producing cool flue gas temperatures, resulting in a 'plume' of vapour being visible at the flue terminal. This plume (steam) is a normal condition of condensing boiler operation and indicates that the appliance is working efficiently. Low level, high level, or vertical flue kits are available, which moves the plume to a higher level. It is also possible to convert an existing low level balanced flue to an external high level or vertical arrangement using our Green System.

Which? Best Buys 2017 & 2018

In the 2018 oil boiler survey produced by the consumer Which?, a coveted Best Buy was awarded to Grant's low NOx boilers including the Vortex Pro Utility and Vortex Pro Combi ranges. Grant is the only oil boiler brand to win a Best Buy for two consecutive years, once again acknowledging the qualities that both consumers and engineers have come to associate with Vortex and VortexBlue boilers. Whether homeowners are looking for a new internal heat-only boiler or an external high performance combi, Grant has a Which? Best Buy oil boiler to meet their requirements.

As the only oil boiler manufacturer to win Best Buys in 2017 and 2018 and with so much choice, Which? Grant boiler will you choose?



VortexBlue Range - Internal Models

The Grant VortexBlue internal models combine our existing proven condensing boiler technology with the latest Riello RDB BLU compact burner.

Our internal range is available in outputs of 15-21kW, 21-26kW and 26-36kW with SAP 2009 gross seasonal efficiencies of between 90.7 and 93.3%.

Features

The boilers feature a sleek white casing, unique control panel with neon diagnostic indicators and simplified pipework arrangement, making them the ideal choice for utility room installations.

Sealed system versions are also available. These include a factory fitted expansion vessel, filling loop, pressure gauge, automatic air vent, pressure relief valve and high efficiency circulating pump, enabling boilers to be installed without the need for a feed and expansion tank in the loft.



Dimensions

All dimensions in mm

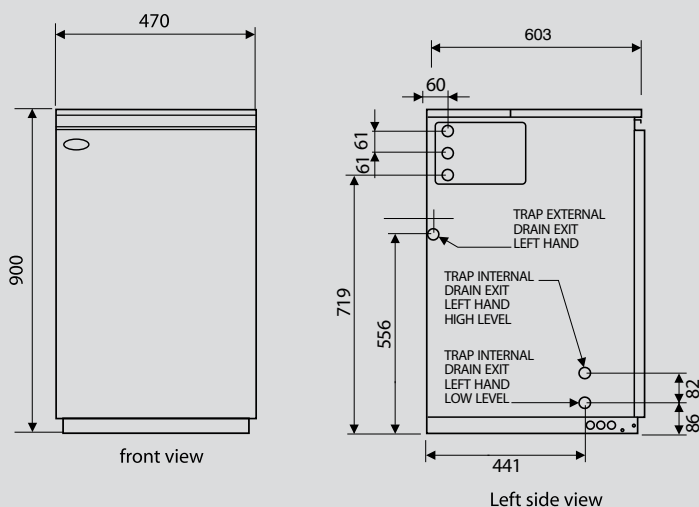
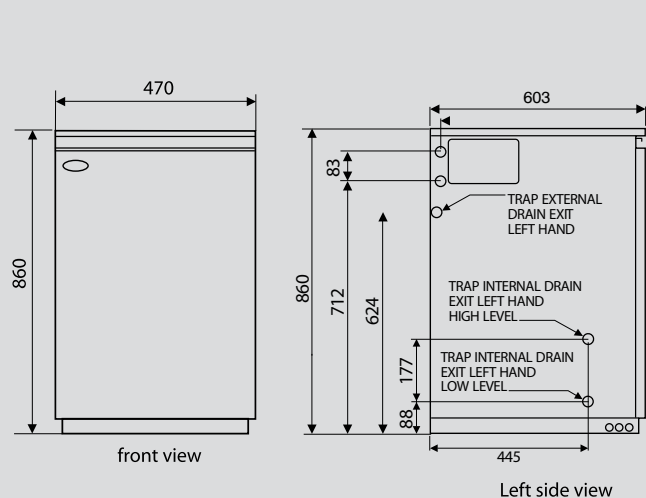

Grant VortexBlue Internal and Internal System 21 & 26

Grant VortexBlue Internal and Internal System 36

Grant VortexBlue Internal Models

VTXBF21 / VTXBF26 / VTXBF36

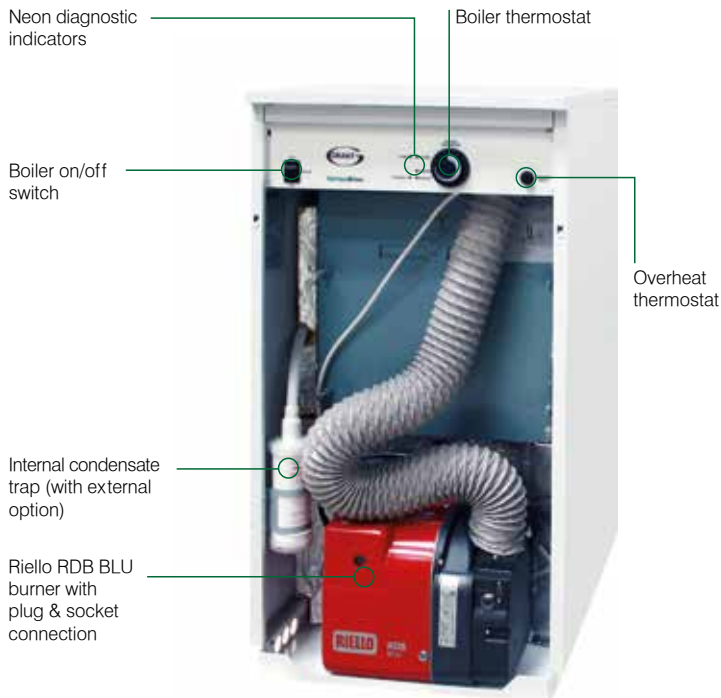

Model shown:
VTXBF26 (front view)

Grant VortexBlue Internal Sealed System Models

VTXSBF21 / VTXSBF26 / VTXSBF36

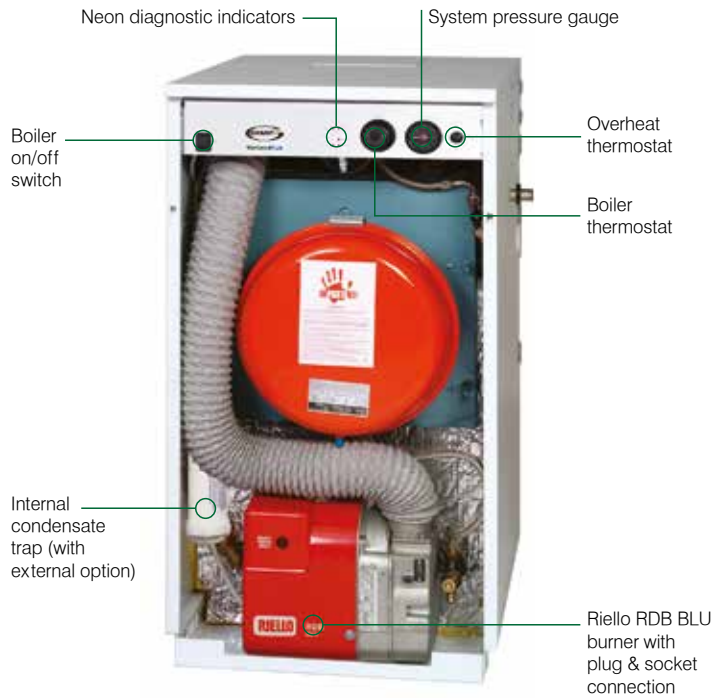

Model shown:
VTXSBF26 (front view)



Technical Specifications

Model	Internal Models			Internal System Models		
	21	26	36	21S	26S	36S
Max Output kW	15-21	21-26	26-36	15-21	21-26	26-36
Max Output Btu/h	50-70,000	70-90,000	90-123,000	50-70,000	70-90,000	90-123,000
Set Output kW	21	26	31.5	21	26	31.5
Flow connection	22mm	22mm	28mm	22mm	28mm	28mm
Return connection	22mm	22mm	28mm	22mm	28mm	28mm
Cold water in (system kit)	n/a	n/a	n/a	15mm	15mm	15mm
Pressure relief (system kit)	n/a	n/a	n/a	15mm	15mm	15mm
Weight (dry)	130kg	130kg	144kg	130kg	130kg	144kg
Condensate pipe	21.5mm OD plastic overflow pipe					

* When installed by a G-One accredited installer. Terms & conditions apply.

Note 1: The boiler flow and return connections exit the casing on the left or right hand side.

Note 2: Grant VortexBlue internal boilers are suitable for fully pumped systems only.

Grant VortexBlue Range - Combi Models

Just like our Internal range, the intelligent VortexBlue Combi incorporates the latest Riello RDB BLU burner technology teamed with our award winning Vortex stainless steel heat exchanger.

The Grant VortexBlue Combi models are available as internal or external models in three sizes - 21kW, 26kW and 36kW.

Features

Featuring large heat exchangers in which, due to their low water content and larger surface area, hot water performance is vastly increased. Additionally, there are two very accurate electronic temperature controls which allow the boiler to operate in condensing mode on central heating, whilst maintaining its instant hot water production.

Benefits include 24ltr expansion vessel, neon diagnostic indicators and a factory fitted internal condensate trap (this can be sited externally if preferred), all designed to make installation and servicing easier. External combi models also benefit from a factory fitted multi-directional flue, high quality external powder coated casing, built in frost protection, mains isolating switch and a test switch.

Typical Hot Water Performance

21kW Combi** 15 litres per minute at an average temperature of 50°C. Recovery time 4 minutes approx. Based upon 100 litre draw off.

26kW Combi** 17 litres per minute at an average temperature of 50°C. Recovery time 4 minutes approx. Based upon 100 litre draw off.

36kW Combi** 20 litres per minute at an average temperature of 50°C. Recovery time 3 minutes approx. Based upon 100 litre draw off.

Mains Water Pressure

Minimum: 2.5bar (36psi). Maximum: 8bar (115psi).

** Hot water flow rate is dependent on mains pressure available. Figures based upon an incoming mains water temperature of 10°C.

Dimensions

All dimensions in mm

Grant VortexBlue Internal Combi 21 and 26

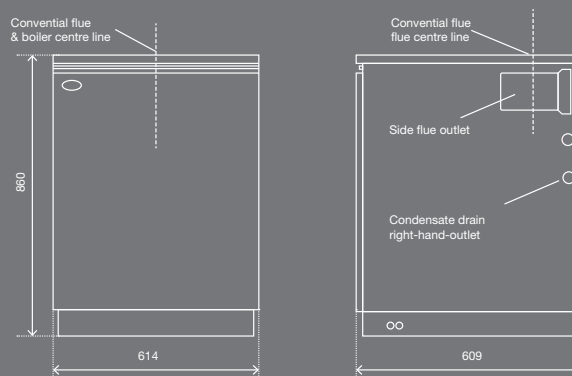

Grant VortexBlue Internal Combi 36

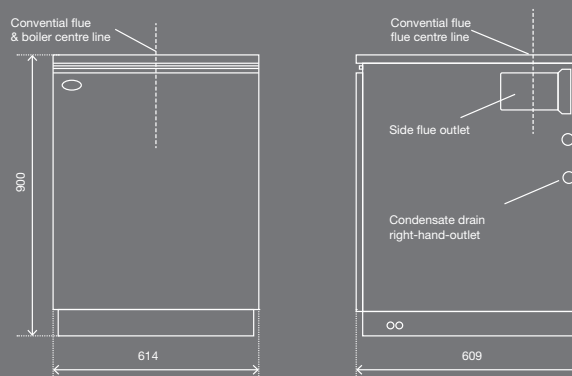

Grant VortexBlue External Combi 21, 26 and 36

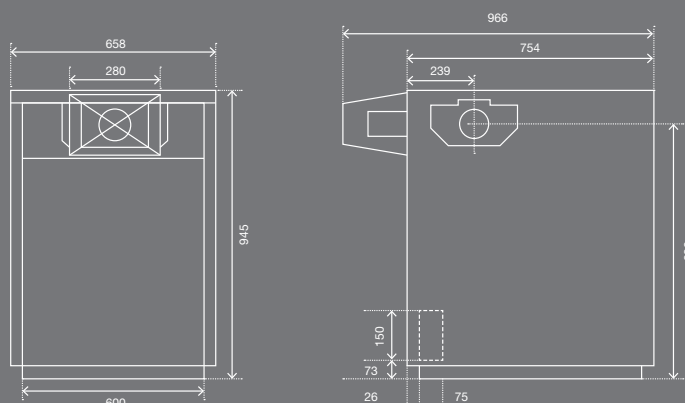

Grant VortexBlue Internal Combi Models

VTXBFCOMBI21 / VTXBFCOMBI26 / VTXBFCOMBI36

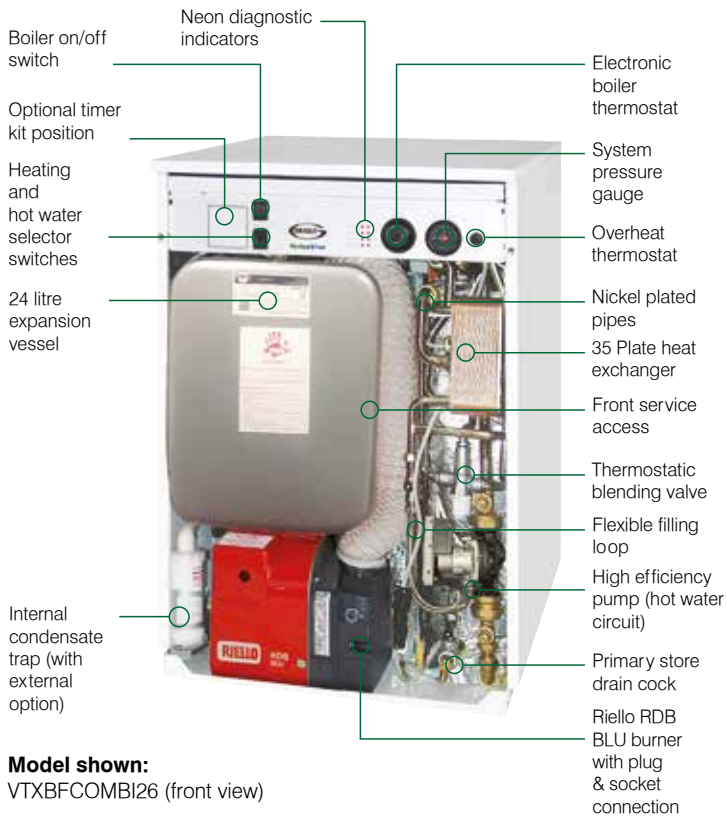

Grant VortexBlue External Combi Modules

VTXBFOMCOM21 / VTXBFOMCOM26 / VTXBFOMCOM36

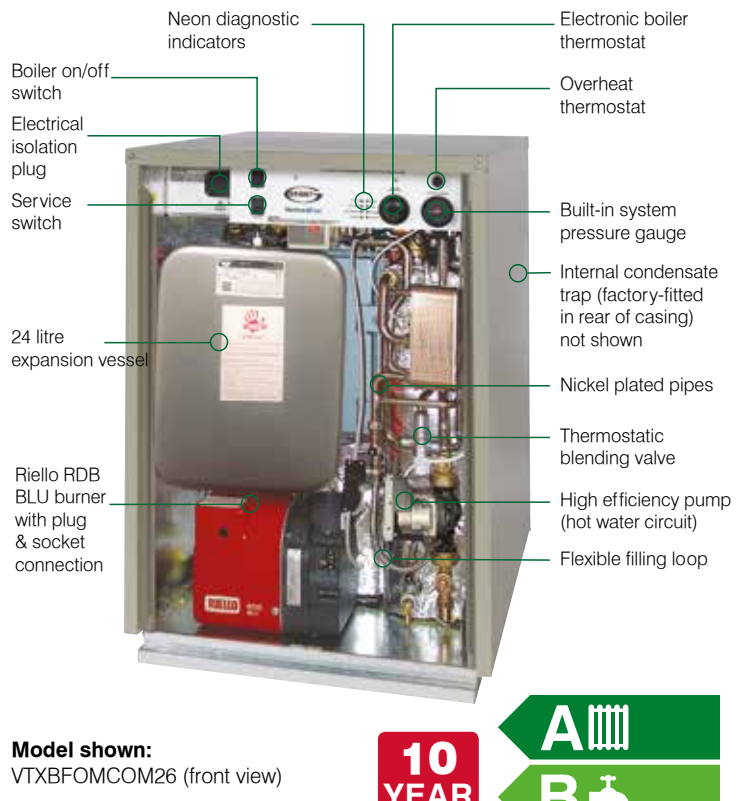

Technical Specifications - Boiler Connections

Model	Internal			External		
	21	26	36	21	26	36
Max Output kW	21	26	36	21	26	36
Max Output Btu/h	70,000	90,000	123,000	70,000	90,000	123,000
Set Output kW	21	26	31.5	21	26	31.5
Flow connection	22mm	22mm	28mm	22mm	22mm	28mm
Return connection	22mm	22mm	28mm	22mm	22mm	28mm
Cold water in	15mm	15mm	22mm	15mm	15mm	22mm
Hot water out	15mm	15mm	22mm	15mm	15mm	22mm
Pressure relief	15mm	15mm	15mm	15mm	15mm	15mm
Weight (dry)	160kg	177kg	200kg	181kg	206kg	225kg
Condensate pipe	21.5mm OD plastic overflow pipe					

* When installed by a G-One accredited installer. Terms & conditions apply.

Note 1: All boiler connections can be positioned to the left or right of the appliance.

Note 2: Grant VortexBlue internal and external combis are suitable for fully pumped sealed systems only.

Grant VortexBlue Range - External Modules

The Grant VortexBlue external module has some of the highest oil-fired boiler efficiencies available today. These models are ideal for situations where a white cased internal version is not always the best solution, possibly due to limited space within the home.

Our external range is available in outputs of 15-21kW, 21-26kW and 26-36kW with SAP 2009 gross seasonal efficiencies of between 90.7 and 93.3%.

Features

All modules include a factory fitted multi-directional flue, high quality external powder coated casing, built in frost protection, mains isolating switch and a test switch. Just as other VortexBlue boilers, this range also incorporates Riellos RDB Blu burner technology teamed with our patented Vortex stainless steel heat exchanger.

Sealed System Kits

Grant VortexBlue external modules can be converted to sealed system operation by purchasing a pre-assembled kit from Grant UK. This includes an expansion vessel (size varies), automatic air vent, pressure relief valve and circulating pump. A filling loop and pressure gauge are also supplied as part of the kit. These can be fitted within the module casing, or ideally in a convenient site within the building, located between the cold main and central heating return.

Boiler model	Sealed system kit part code
VTXBFOM21	VTXOMSSKIT26
VTXBFOM26	VTXOMSSKIT26
VTXBFOM36	VTXOMSSKIT46

Dimensions

All dimensions in mm

Grant VortexBlue External 21, 26 & 36

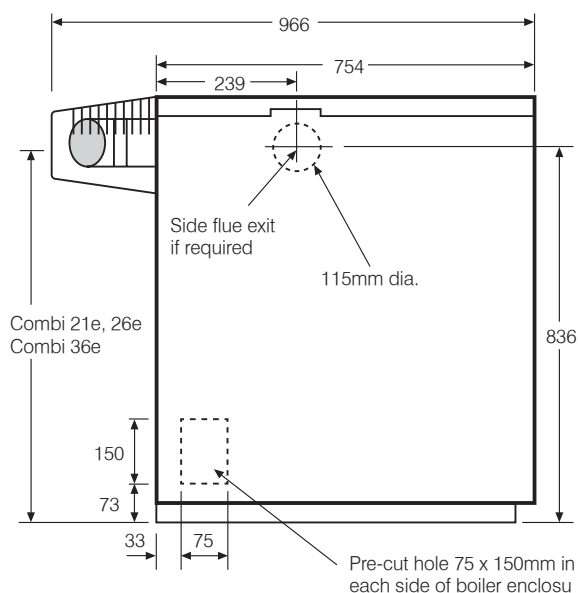
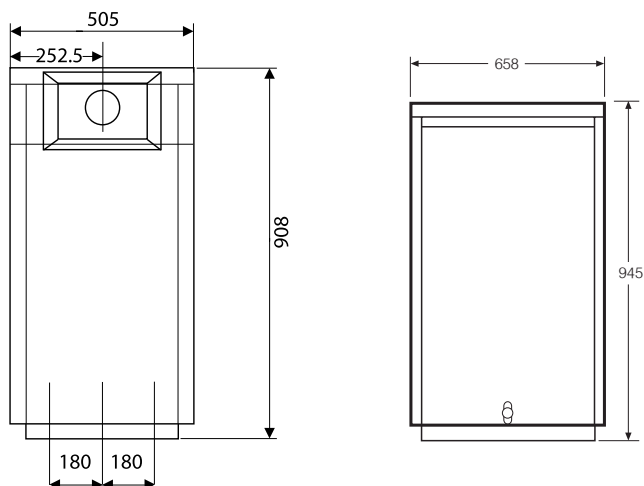

Grant VortexBlue External Modules

VTXBFOM21 / VTXBFOM26 / VTXBFOM36

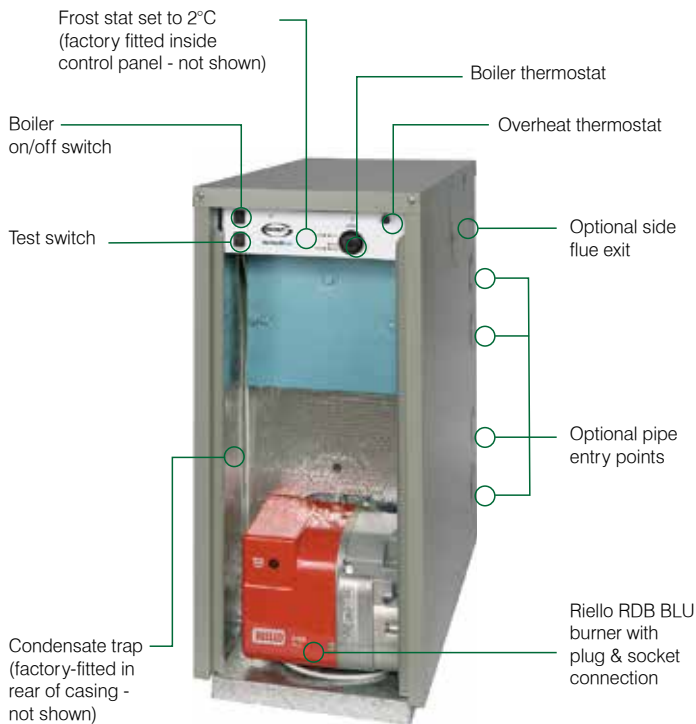

Model shown: VTXBFOM26 (front view)



Technical Specifications - Boiler Connections

Model	External Modules		
	21	26	36
Max Output kW	15-21	21-26	26-36
Max Output Btu/h	50-70,000	70-90,000	90-123,000
Set Output kW	21	26	31.5
Flow connection	22mm	22mm	28mm
Return connection	22mm	22mm	28mm
Cold water in (system kit)	15mm	15mm	15mm
Pressure relief (system kit)	15mm	15mm	15mm
Weight (dry)	143kg	143kg	162kg
Condensate pipe	21.5mm OD plastic overflow pipe		

* When installed by a G-One accredited installer. Terms & conditions apply.

Note 1: All boiler connections can be positioned to the left or right of the appliance.

Note 2: Grant VortexBlue modules are suitable for fully pumped systems only.

Grant Vortex **MagOne Magnetic Filter**

The MagOne (Part code: VM01) provides innovative protection for your Grant Vortex oil-fired boiler and central heating system up to 36kW. For larger systems you can fit two MagOnes in a parallel circuit.

Using a simple to install, triple action filtration design, the easy clean/easy drain MagOne filters magnetite and non-ferrous debris from central heating systems with a 12,000 gauss neodymium magnet. The unit is also compatible with all system inhibitors and glycol solutions.

Features

- Manual air bleed
- 500ml dosing capacity
- 360° installation
- 6 bar max working pressure
- Installation/servicing date wheel
- 120°C max working temperature
- Full bore flat face 28mm isolation valves
- Complete with 28-22mm reducers
- Supplied with spare sealing washers & o-rings





**LOW
NOx**

**The only oil boiler
with a Which?
Best Buy for the
second year running.**

#MustBeVortex

Up to
5 year
guarantee*



Best Buy

Which?

Oil Boilers September 2018



www.grantuk.com



* Subject to full T&C's and status ** SAP 2009

**VORTEX PRO UTILITY
RANGE**

Tried & trusted Riello Low NOx burner technology

Awarded the coveted Which? Best Buy for the second year running

Internal & external models with outputs from 15-70kW

Exceptional seasonal efficiency of up to 93.3%**

Also available in the Vortex Range:

**VortexBlue
Vortex Eco
Vortex Boiler House**

Installation and Commissioning

Installation must comply with the current British Standards and The Building Regulations. Comprehensive technical information can be found in the installation manual, supplied with every boiler. As with all oil-fired appliances, Grant VortexBlue condensing boilers require commissioning at the time of installation. This simple process ensures that the boiler is working at peak efficiency which, in turn, will result in lower running costs and long term reliability.

Guarantees

Grant Engineering (UK) Limited guarantees the manufacture of the boiler including all electrical and mechanical components for a period of **twelve months from the date of installation**, unless the installation was more than six months from the date of purchase, in which case the guarantee period will commence six months from the date of purchase, provided that the boiler has been installed in full accordance with the installation and servicing manual issued. This will be extended to a total period of **two years** if the boiler is registered with Grant Engineering (UK) Limited **within thirty days of installation** and serviced at twelve monthly intervals. To register your boiler visit: www.grantuk.com. The shell (heat exchanger) of the boiler is also covered by a **five year parts only** guarantee from the date of purchase. This is subject to the following:

- a) The boiler is operated correctly, in accordance with the installation and servicing manual.
- b) Proof is provided that the system has been flushed or chemically cleaned where appropriate (refer to BS 7593) and the required quantity of a suitable corrosion inhibitor added.
- c) Proof of annual servicing (including the checking of any expansion vessels and pressure relief valves) must be provided if and when requested by Grant Engineering.

IMPORTANT - Grant Engineering (UK) Limited **strongly recommends** that a MagOne in-line magnetic filter is fitted in the heating system pipe work. This should be installed and regularly serviced in accordance with the installation instructions.



Grant Engineering (UK) Ltd

Hopton House, Hopton Industrial Estate,
Devizes, Wiltshire, SN10 2EU

t: +44 (0)1380 736920 f: +44 (0)1380 736991

e: sales@grantuk.com w: www.grantuk.com



Aftersales Service

For peace of mind, Grant VortexBlue boilers are backed by a national network of independent service engineers. In the unlikely event of a problem occurring, your installer should telephone our Customer Service Department on: **+44 (0)1380 736920**.

Flue Systems

All Grant VortexBlue oil-fired boilers are supplied for connection to one of Grant's EZ-Fit flue options either conventional or balanced. The balanced flue systems are available as low level, high level or vertical kits, for internal and external applications, and even as unique EZ-Flexi packs, designed to enable condensing boilers to utilise an existing chimney. All EZ-Fit flues carry the CE mark of approval and are adaptable to any installation.

Fuel

The Riello RDB BLU burner on a Grant VortexBlue boiler is supplied factory set at the stated output for use on standard grade kerosene - Class C2.

IMPORTANT - Grant VortexBlue condensing boilers must not be used with Class D gas oil or biokerosene.

This leaflet is accurate at the time of printing but as Grant UK has a policy of continual improvement it may be superseded. We reserve the right to amend specifications without prior notice. The statutory rights of the consumer are not affected. All products manufactured under I.S. EN ISO 9001. Grant UK additionally holds ISO 14001 accreditation. TMTHE GRANT 'EZ-FIT FLUE' SYSTEM is a trade mark of Grant Engineering Limited.

@Grant Aerona, Grant Spira, Grant Vecta, Grant Vortex, Grant VortexBlue, Grant VortexAir, Grant Solar, Grant Aurora, Grant Sahara, Grant CombiSOL, Grant WinterSOL, Grant MonoWave, Grant DuoWave, Grant ThermaWave, Euroflame and Multi Pass are registered trade marks of Grant Engineering Limited. The contents of this leaflet are fully protected by copyright and nothing may be reproduced without permission from Grant

